



UPLIFTING COMPANY

**AUTOP** **STENHOJ**

**Premium lifting technology for electric vehicles**





## Masterlift 2.35 Pv 180-240 KA 1700

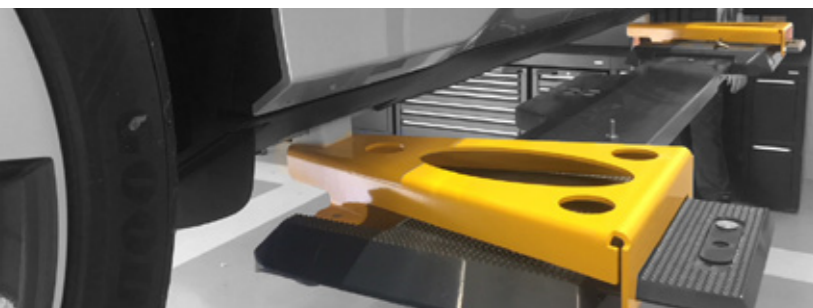

The Masterlift 2.35 Pv 180-240 with piston distance (KA) 1700 can safely lift the most common electric vehicle models currently available.

- Audi e-tron
- Audi e-tron SUV
- BMW i3
- BMW i8
- BMW i20
- Porsche Taycan
- Polestar 2
- Tesla Model 3
- Tesla Model S X
- VW ID 3
- Jaguar / Landrover
- etc.

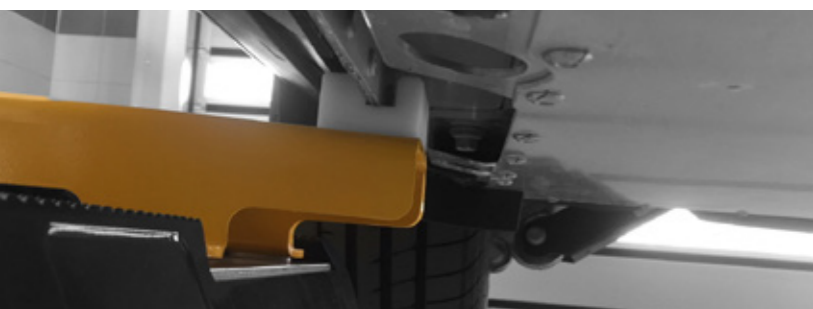

The Masterlift 2.35 Pv 180-240 is an electro-hydraulic twin-ram lift with a lifting capacity of 3.5 t.

The stable repair platforms, lengthwise adjustable can be turned around 180° for safe lifting of standard or electric/hybrid vehicles.

The adaptors were specially developed for the safe lifting of electric vehicles with very reduced lifting points.



## Masterlift 2.35 Combi KA 1700



The Masterlift 2.35 Combi with piston distance (KA) 1700 is the perfect lift for your reception area and for simple repair work. In addition, it can safely lift the most popular electric vehicle models currently available thanks to the Pv 180-240 repair platform.

- Audi e-tron, Audi e-tron SUV
- BMW i3, BMW i8, BMW i20
- Porsche Taycan
- Polestar 2
- Tesla Model 3, Tesla Model S X
- VW ID 3
- Jaguar / Landrover
- etc.

The Masterlift 2.35 Combi KA 1700 is an electro-hydraulic 2x2 ram lift with a lifting capacity of 3.5 t - drive-on platform and independent wheel-free combined in one single lift.

The platforms have integrated roll-off safety devices and are covered with aluminum tear plate. The LED lighting is recessed into the platforms surface, incl. 2 recesses for high-current plug for battery charger „Anderson SB120“ (not included in the scope of delivery).

The stable repair platforms, lengthwise adjustable can be turned around 180° for safe lifting of standard or electric/hybrid vehicles.

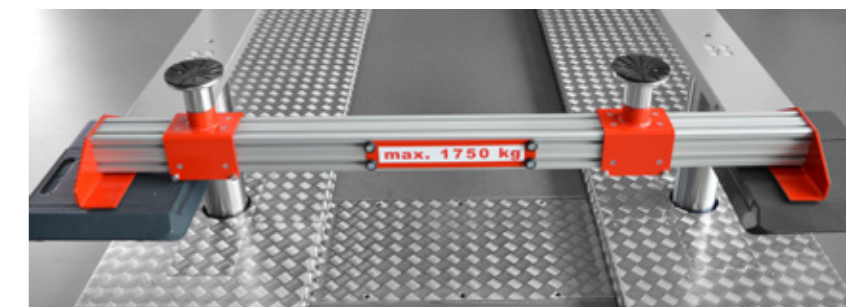
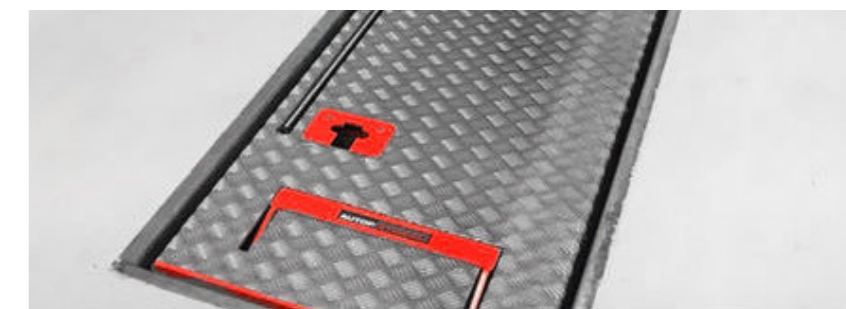

## Masterlift 2.35 Pv 180-240 KA 1700 Wide platform distance

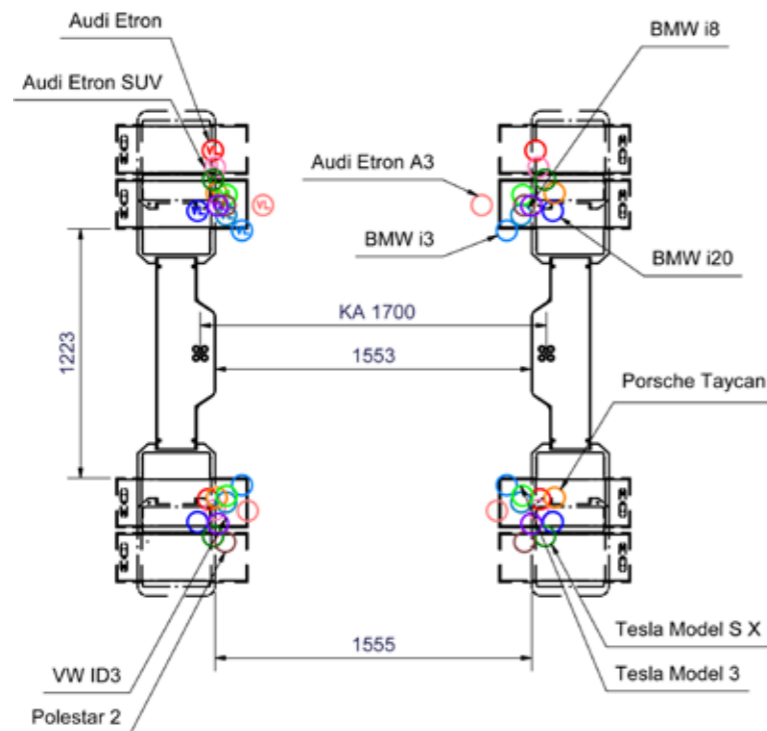

## Masterlift 2.35 Pv 180-240 KA 1700 Small platform distance

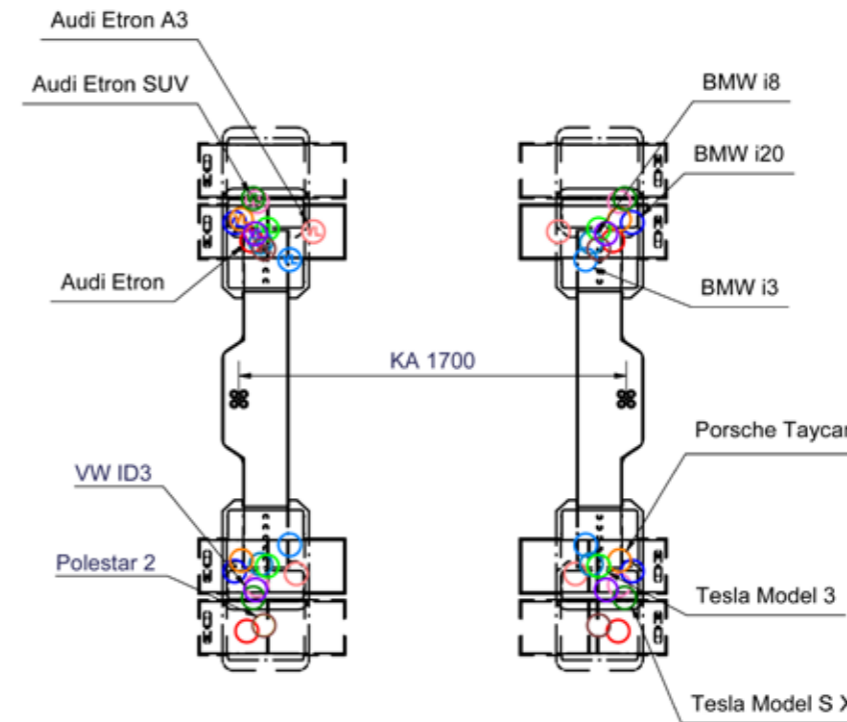

## Maestro 2.35 NxT ST-DT (T12420)

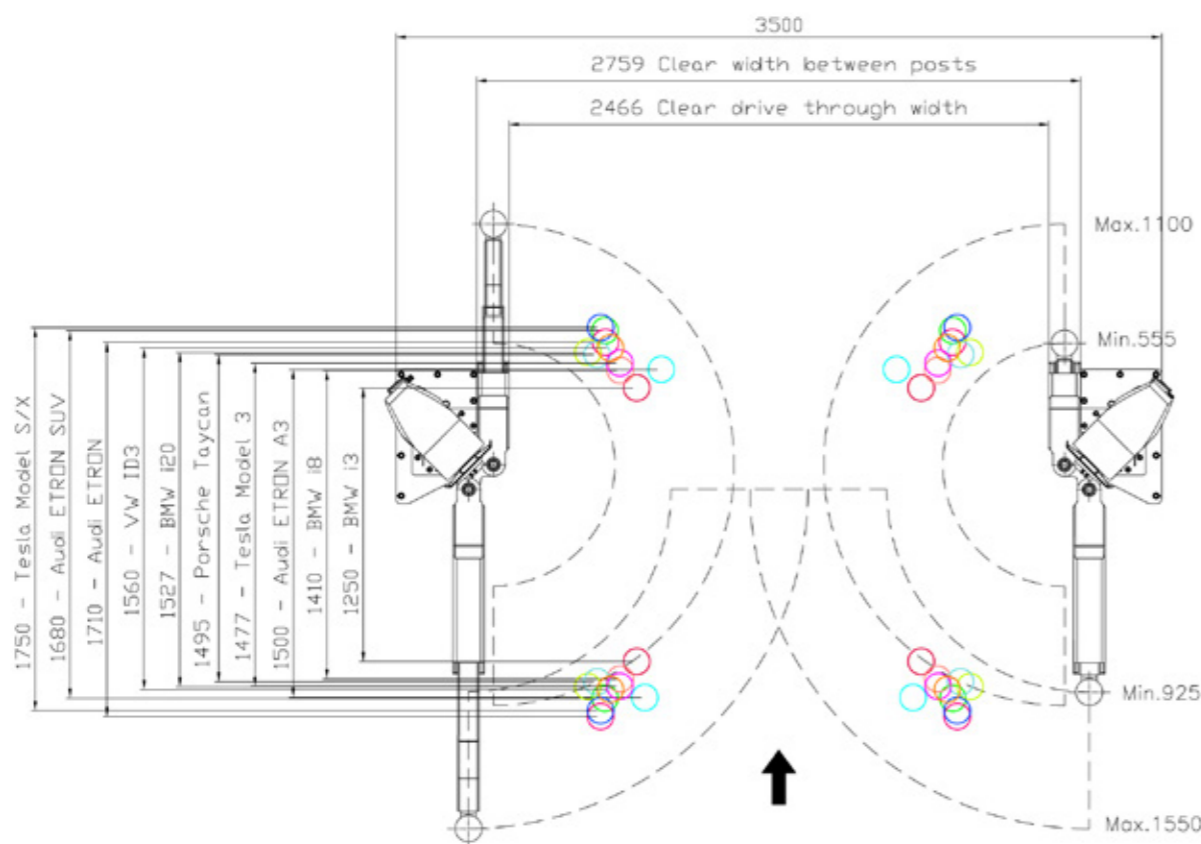

## Masterlift 2.35 Saa 230/260

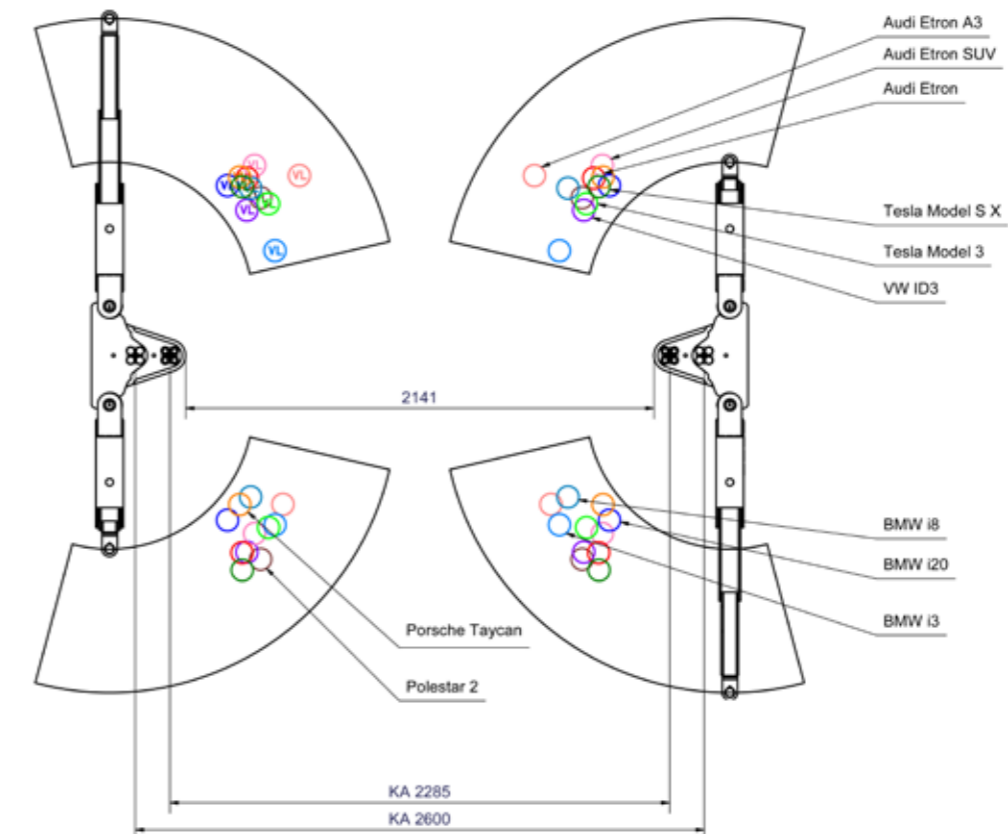



## Maestro 2.35

The Maestro 2.35 is the bestseller among the surface-mounted lifts, the all-rounder for the repair and maintenance sector and is also the solution for lifting electric cars.

- Audi e-tron, Audi e-tron SUV
- BMW i3, BMW i8, BMW i20
- Porsche Taycan
- Tesla Model 3, Tesla Model S/X
- VW ID 3
- etc.

The Maestro 2.35 is a mechanical 2-post lift with 3.5 t lifting capacity for the highest quality demands. A welded column construction, carriage with 6 guiding wheels and lubrication-free roller bearings, with a nylon nut set on cold rolled spindles guarantee an extremely long service life.

Thanks to the large choice of accessories, even the most modern e-cars cause no problem for professional and expert lifting. With the F, CF and CF-08 pads, no wishes remain unfulfilled.

The Maestro 2.35 is available with standard swivel arms as well as with extra-flat swivel arms in the sports version. This means that the workstation can be used in a variety of ways, for „normal“ cars and vans, for sports cars and, of course, also for e-cars.

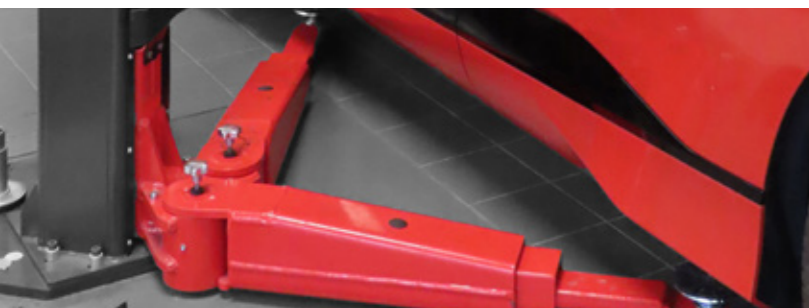

## Masterlift 2.35 Saa 230/260

The Masterlift 2.35 Saa 230/260 is the bestseller among the inground lifts, the all-rounder for repair, maintenance and bodywork and is also the solution for lifting electric cars.

- Audi e-tron, Audi e-tron SUV
- BMW i3, BMW i8, BMW i20
- Porsche Taycan
- Tesla Model 3, Tesla Model S/X
- VW ID 3
- etc.

The Masterlift 2.35 Saa 230/260 is an electro-hydraulic twin-ram lift with a lifting capacity of 3.5 t and can be installed with piston distances of 2,300 mm or 2,600 mm.

With this lift, you can lift particularly flat sports cars or vans such as the Sprinter. In addition, the same lift also lifts vehicles such as the Audi e-tron without any problems and the underbody remains freely accessible.

A standard workstation that can also be used as a workstation for electric vehicles. Thus there is no need to invest in a stand-alone „electric vehicle workstation“. You create a conventional workstation for repair, maintenance and bodywork, which you can also use for e-cars.

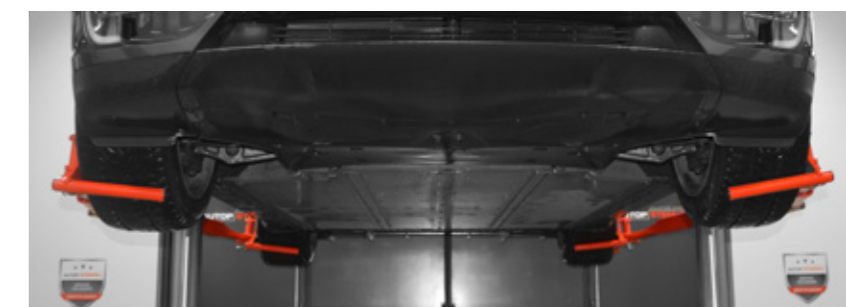

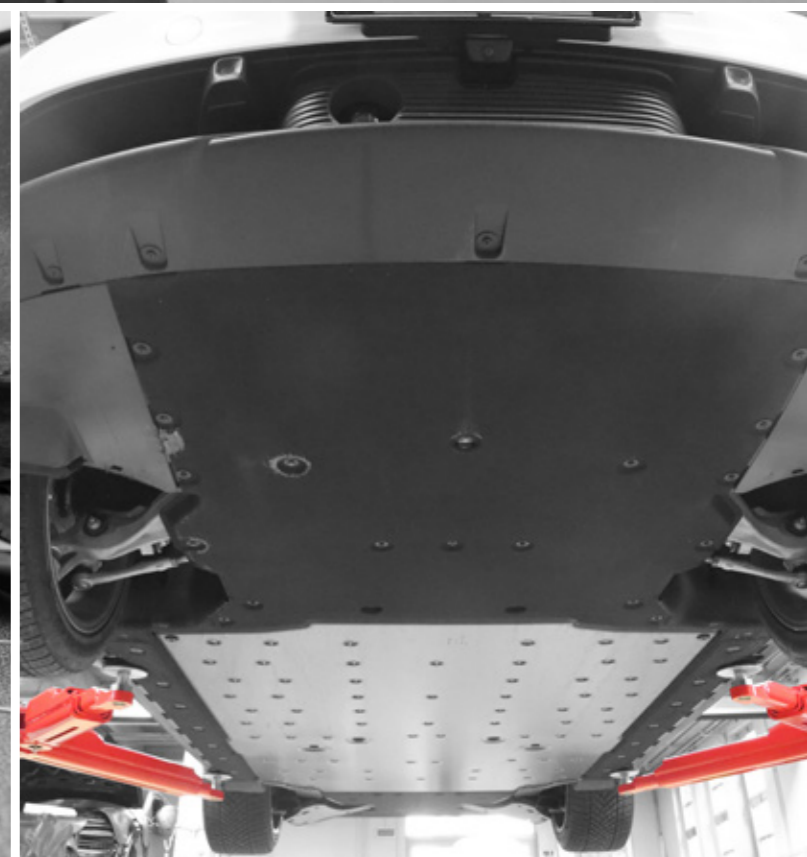
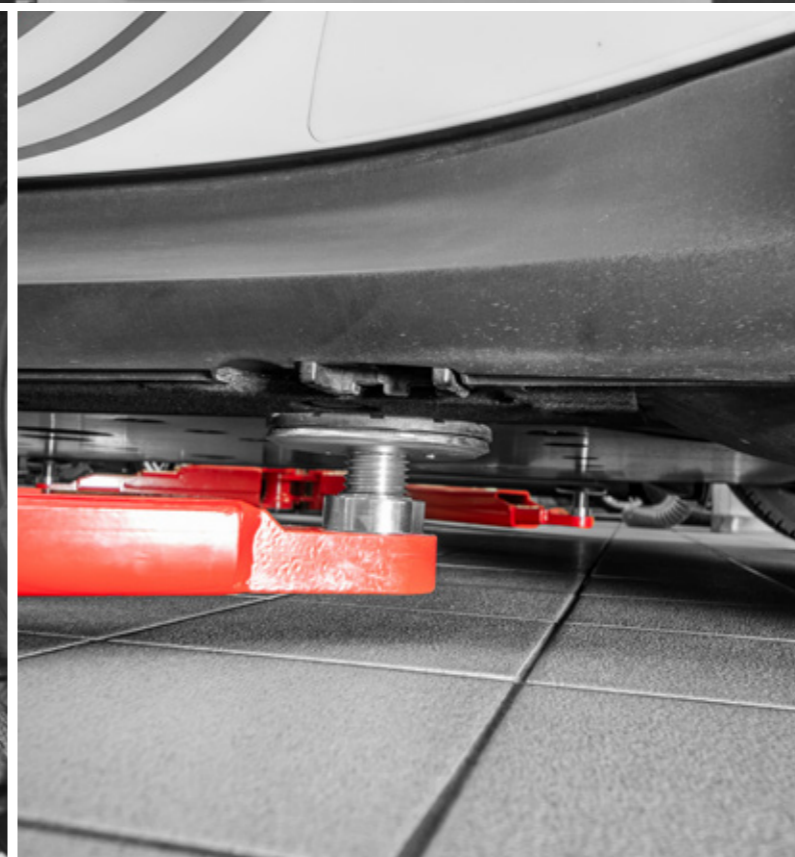

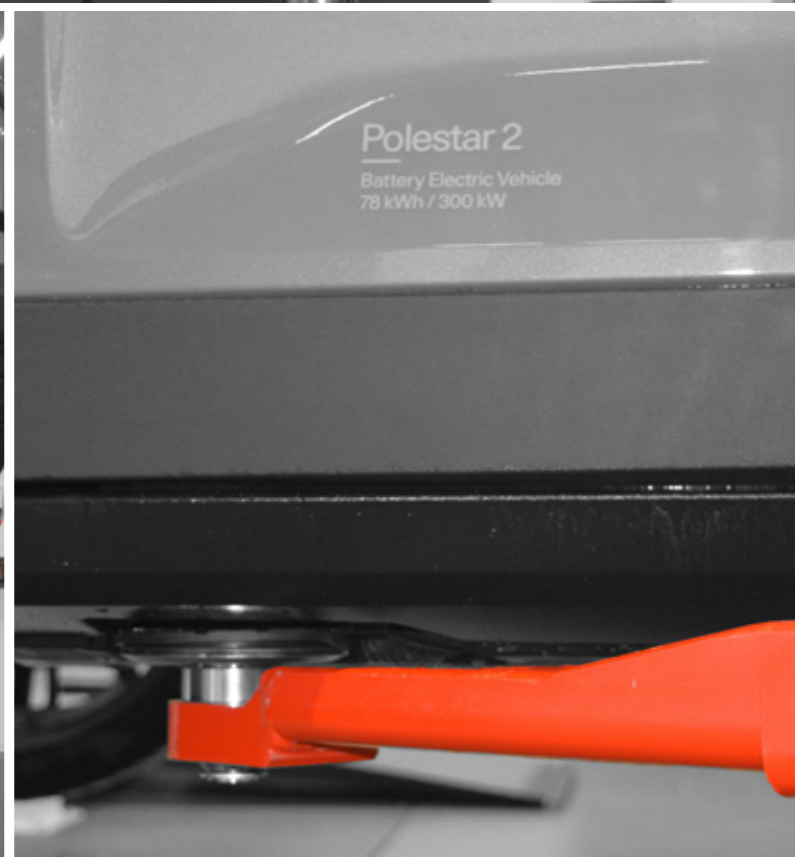



UPLIFTING COMPANY

**AUTOP** **STENHOJ**



**AUTOPSTENHOJ GmbH**  
Sandkampstr. 90 | D -48432 Rheine  
☎ +49 5971 8602-02  
✉ info@autopstenhoj.com

**AUTOPSTENHOJ GmbH**  
Barrit Langgade 188-190 | DK-7150 Barrit  
☎ +45 76 82 13 30  
✉ info@autopstenhoj.com