

Sololift 1.35 Saa Ø 213

Electro-hydraulic single-ram lift, 3.5 t capacity, superstructure with arms

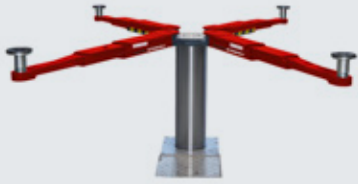

Application

- Repairs and maintenance
- Body work

Approvals / recommendations

- Renault
- Volkswagen Group

Description:

Steel cassette:

- Waterproof steel cassette
- Self-carrying

Hydraulic unit:

- Hard-chrome plated cylinder
- High stability (Cyl.-Ø213mm)
- Integrated anti-rotation device
- Corrosion-free guiding elements
- Pump unit with immersed motor for fitting in floor
- Hydraulic oil
- Pneumatic emergency lowering
- Programmable pushbutton control unit
- Alarm signal / CE-stop

Superstructure:

- Double telescopic arms
- Internal arm locking system
- Low minimum height

Standard colours:

- Base plate: RAL 7016 - grey
- Arms: RAL 3020 - red

Versions:

Steel cassette:

- Hot galvanized
- Coated

Installation:

- Superstructure on floor
- Ceiling installation
- Hydraulic pump unit in floor

Optional extras:

- Large program of extra pads

Special colours available on request!



Click the QR-Code for detailed product information.

Further Information on www.autopstenhoj.com

AUTOPSTENHOJ GmbH

Sandkampstraße 90

D-48432 Rheine

+49 5971 8602-02

info@autopstenhoj.com

Technical data	
Lifting capacity	3,500 kg
Lifting height	1,910 mm
Working height	2,005 - 2,045 mm
Cylinder diameter	213 mm
Lifting / lowering time (high pressure)	approx. 30 sec.
Foundation depth	2,650 mm
Pump unit	3 kW
Hydraulic oil	14 l
Voltage	230 / 400 V – 50 Hz – 16 A

Arm superstructure	
Min. height with pad No.	11027 (95 - 135 mm)
Arm length, min. - max.	636 - 1,290 mm
Construction height	94 mm

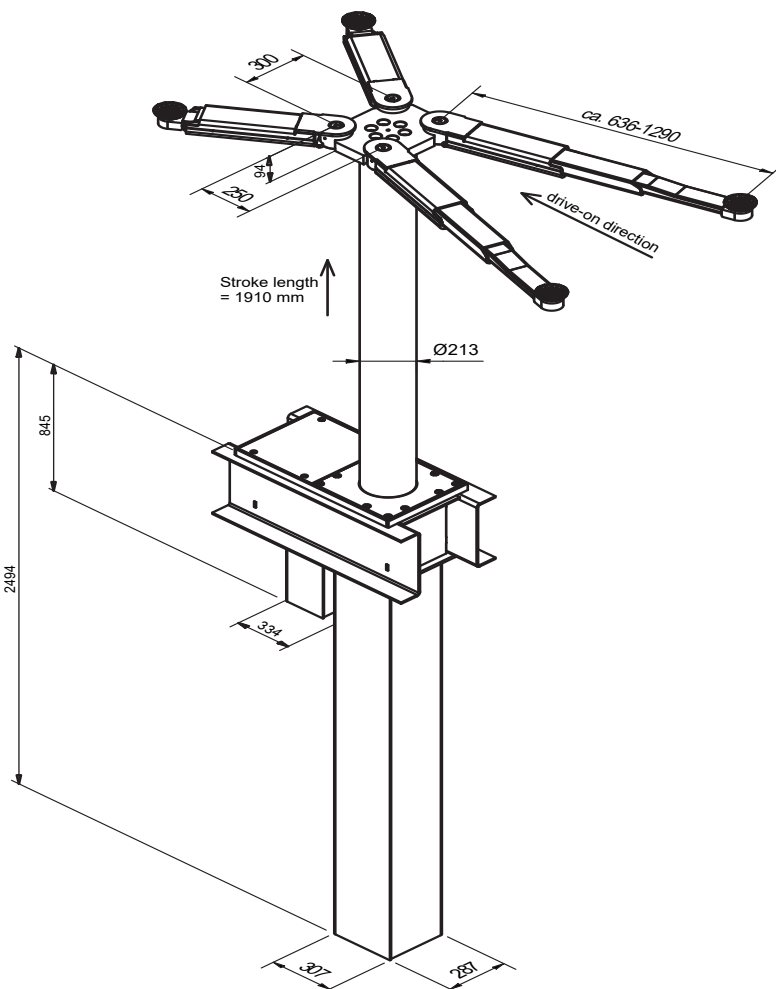

Corrosion-free guiding elements



Internal arm locking system



Hard-chrome plated cylinder